



BLACK CAT
WEAR PARTS



H&L®
BACKHOE LIPS

With Integrated 23 Series Adapters

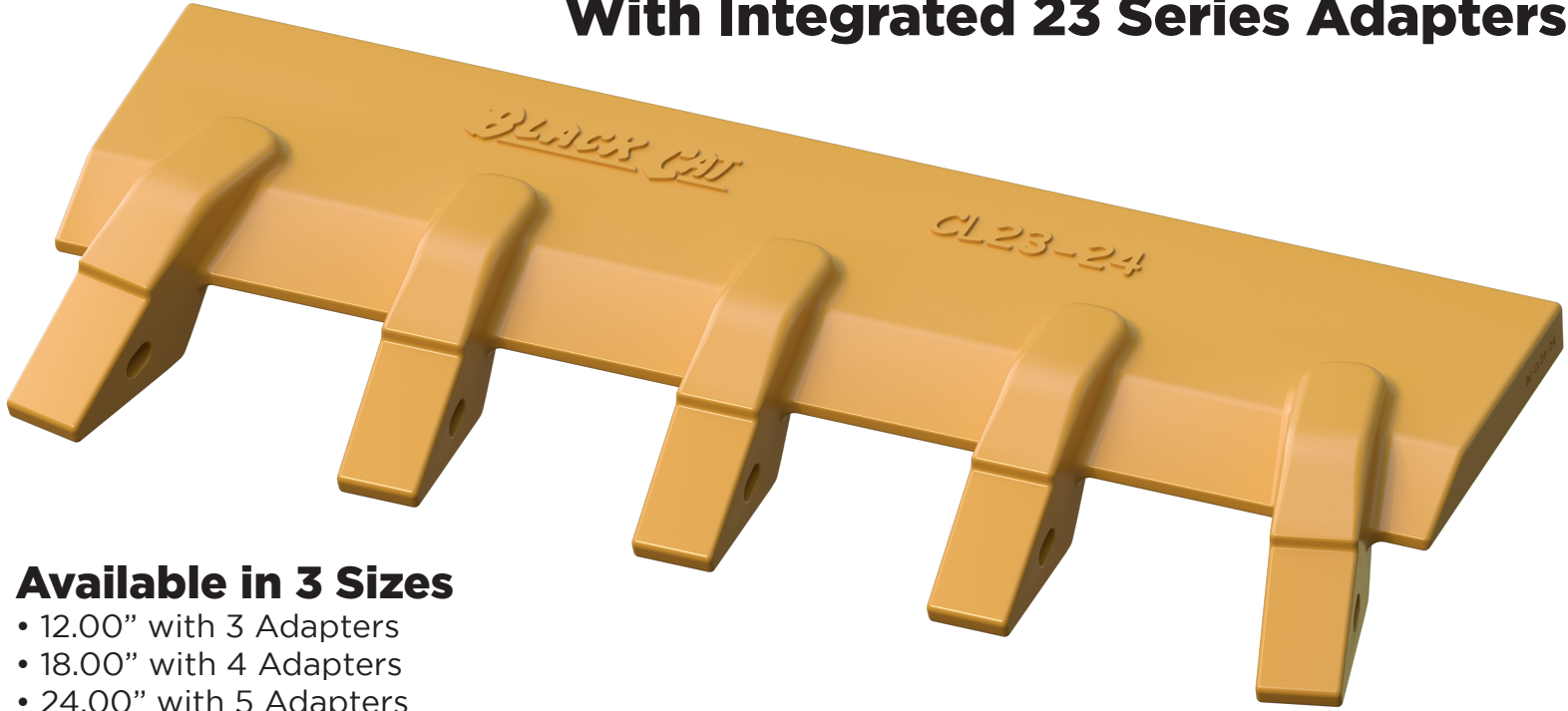

Available in 3 Sizes

- 12.00" with 3 Adapters
- 18.00" with 4 Adapters
- 24.00" with 5 Adapters

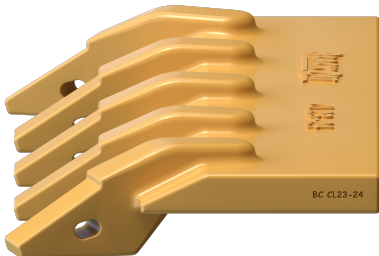
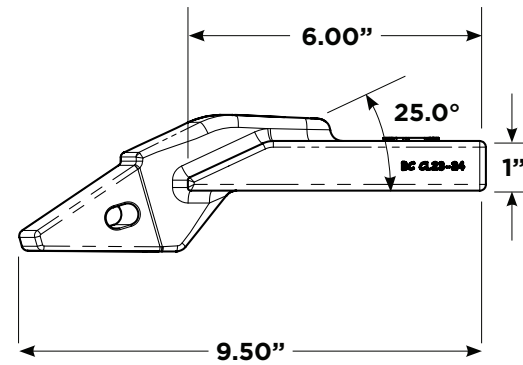
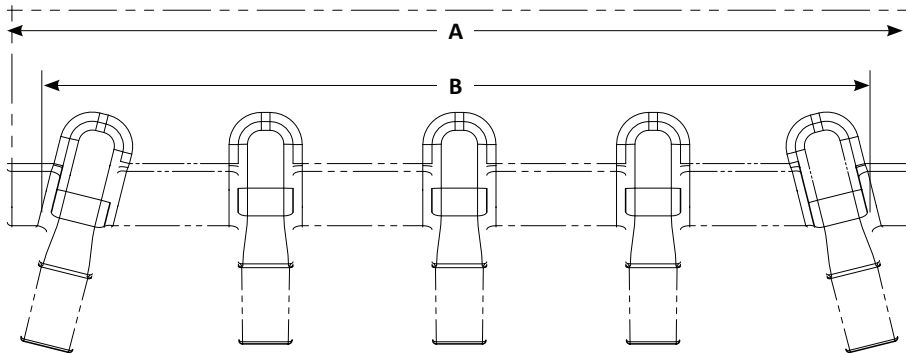

Bucket Width	Part Number	No. of Adapters	Weight	A	B
12.00" 305 mm	CL23-12	3	27.5 lb 12.5 kg	12.60" 321 mm	10.70" 272 mm
18.00" 457 mm	CL23-18	4	38.0 lb 17.2 kg	18.50" 470 mm	15.60" 397 mm
24.00" 610 mm	CL23-24	5	52.0 lb 23.6 kg	24.50" 622 mm	22.30" 567 mm

Caterpillar® and other identities and/or trademarks referred to in this publication are the registered marks of the entities noted herein. The use of any trademarks of others than Black Cat Wear Parts Ltd. are solely and exclusively for identification, informational, comparative, and descriptive purposes. Black Cat Wear Parts Ltd. is not affiliated with any owner of such registered marks and does not make, use, or sell any products manufactured by any such entity identified in this publication.

www.blackcatwearparts.com
sales@blackcatwearparts.com
 +1-780-465-6666
 1-800-661-6666

**STRONG ENOUGH
TO ANSWER ANY CALL!**